

NOTES (UNLESS OTHERWISE SPECIFIED)

1. ARM SHOWN IN OPEN POSITION IN ALL VIEWS.
2. P/N 24072 (WRENCH TO BE SHIPPED WITH VALVE).

**ENGINEERING APPROVED COPY
FOR MANUFACTURE**

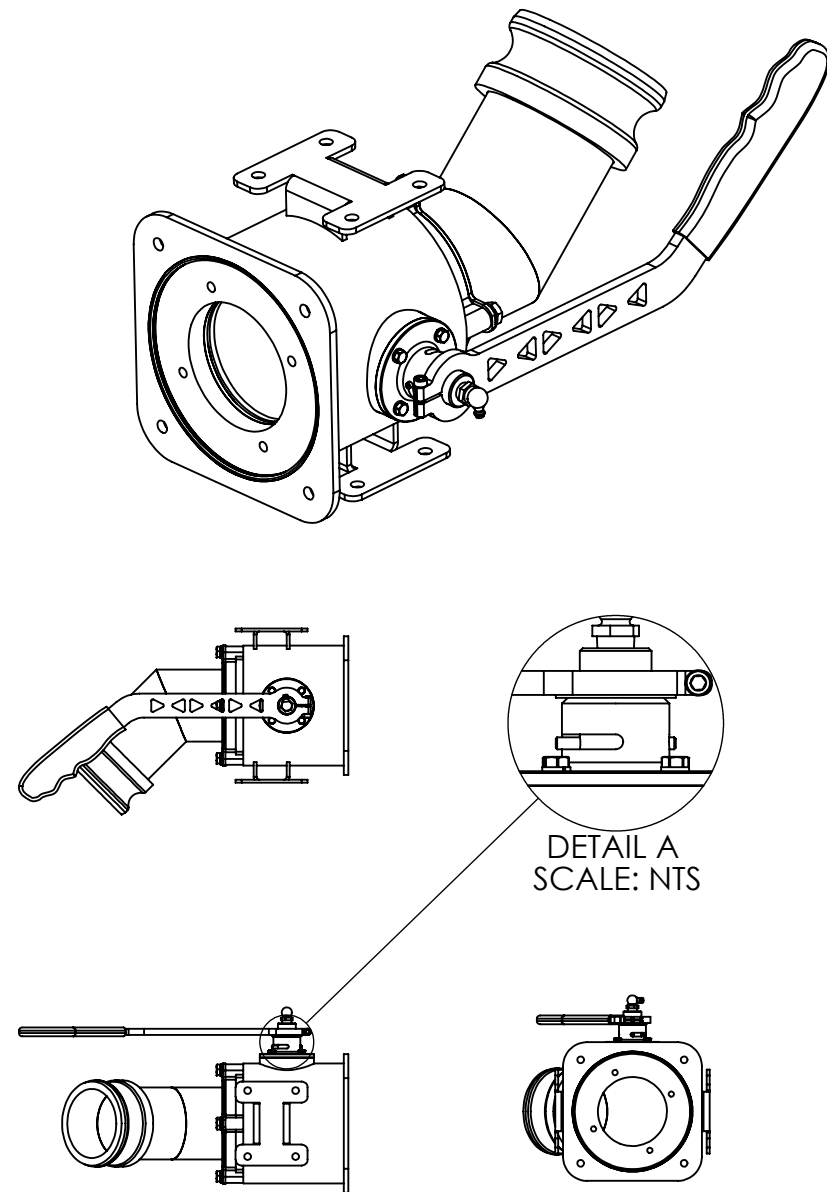

ITEM NO.	PART NO.	NO. REQD	DESCRIPTION	SIZE	SPEC.	NO. REQD	NEXT ASSEMBLY	FINAL ASSEMBLY
			MATERIAL					
H	22	4	WASHER, LOCK (81195)					
F	21	4	BOLT, HX HD (80102)					
	20	1	SCREW (80180)					
	19	4	BOLT, HX HD (80373)					
C	18	4	WASHER, LOCK (80778)					
	17	1	ROLL PIN (86310)					
	16	1	GREASE FITTING (86180)					
	15	1	GRIP (82326)					
	14	1	O-RING (81633)					
	13	1	O-RING (81632)					
	12	1	O-RING (81603)					
	11	1	O-RING (81631)					
	10	1	ARM					
	9	1	WASHER					
	8	1	VALVE STEM					
	7	1	VALVE STEM HOUSING					
G	6	1	PLUG CAP/SST VLV WHITE TEFLON					
	5	1	ENDCAP					
	4	1	RING SEAT					
	3	1	BALL					
	2	2	TEFLON SEAT					
	1	1	3" SST LOADER VALVE BODY FINAL WELDMENT					

REV.	E.O.	DESCRIPTION	BY	DATE	APPR'D	DATE
H	8943	NEW TITLE BLOCK	RC	6/27/16	CLK	6/28/16
G	3649	ADDED ITEM 6 P/N 15695 QTY 1 & NOTE 2	PK	11/29/12	JMV	11/30/12
F	894	ITEM 21 PN-80102 WAS 80104	PK	2/21/11	JMV	2/22/11
E	-	REDRAWN & UPDATED GEOMETRY TO REFLECT CHANGES TO PARTS	JMV	12/14/09	JMV	12/15/09
D	-	80104 WAS 80108	JMV	12/9/09	JMV	12/10/09
C	-	81195 WAS 81203 ; 80778 WAS 81202	JMV	10/13/09	JMV	10/14/09
B	-	REDESIGN	JMV	7/28/09	JMV	7/29/09

REVISIONS

NAME	DATE
DRAWN LDT	8/3/09
CHECKED RR	6/27/16
ENG APPR. CLK	6/28/16

UNLESS OTHERWISE SPECIFIED:
DIMENSIONS ARE IN INCHES

TOLERANCES:
FRACTIONS ±1/16
.XX ±.03
.XXX ±.010
ANGLE ± 1/2°

HOLE DIA:
.0135 - .125 DIA. +.004 -.001
.1260 - .250 DIA. +.005 -.001
.2510 - .500 DIA. +.006 -.001
.5010 - .750 DIA. +.008 -.001
.7510 - 1.000 DIA. +.010 -.001

REMOVE ALL BURRS AND SHARP EDGES
INTERPRET DRAWING PER ANSI Y14.5M-1982
SURFACE ROUGHNESS PER MIL-STD-10
ALL MACHINED SURFACES NOT TO EXCEED 63 MICROINCHES PER MIL-STD-10 UNLESS NOTED

SolidWorks

THIRD ANGLE PROJECTION



1206 HATTON ROAD, WICHITA FALLS, TX 76302

TITLE: **3" SST RH, A/T 45° LOAD VALVE**

SIZE **B** DWG. NO. **54804** REV **H**

SCALE: NTS MODEL: SHEET 1 OF 2

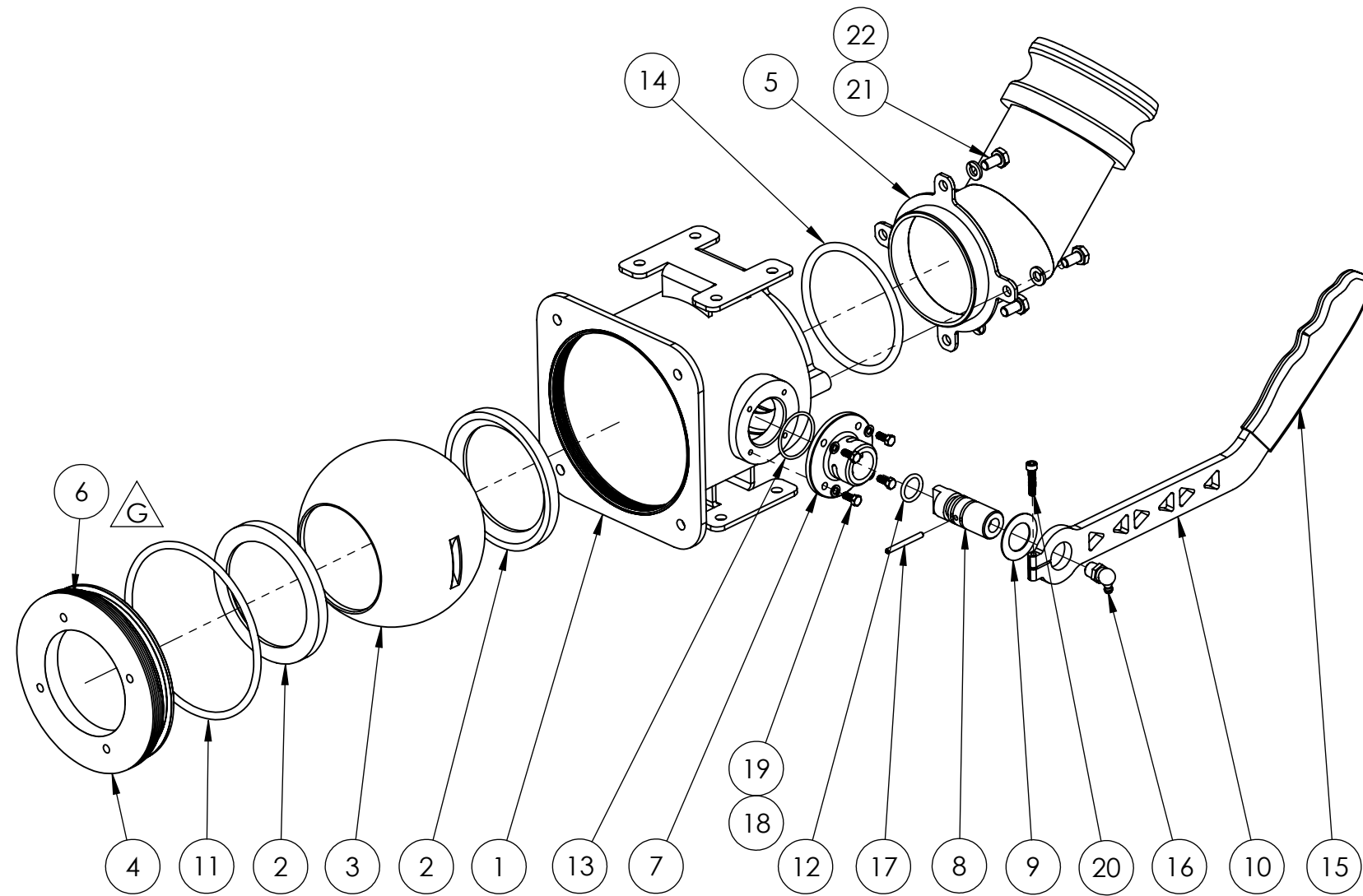

1206 HATTON ROAD, WICHITA FALLS, TX 76302

TITLE: 3" SST RH, A/T 45° LOAD VALVE

SIZE B	DWG. NO. 54804	REV H
SCALE: NTS		SHEET 2 OF 2