

NOTES:

1. PART IS INTERCHANGEABLE WITH P/Ns 29540 & 29541.
2. SPOT WELD ITEMS 1 AND 2 TOGETHER IN FLAT PATTERN.
3. FORM TO DIMENSIONS REQUIRED AND SPOT WELD AS REQUIRED.

ITEM NO.	PART NUMBER	DESCRIPTION	QTY.
1	13999	SCREEN - 40 MESH	1
2	14837	SCREEN	1
3	19530	SCREEN HANDLE	1

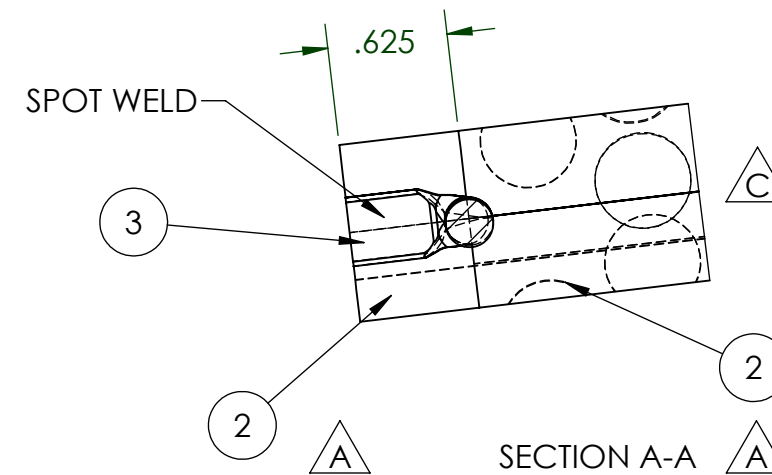
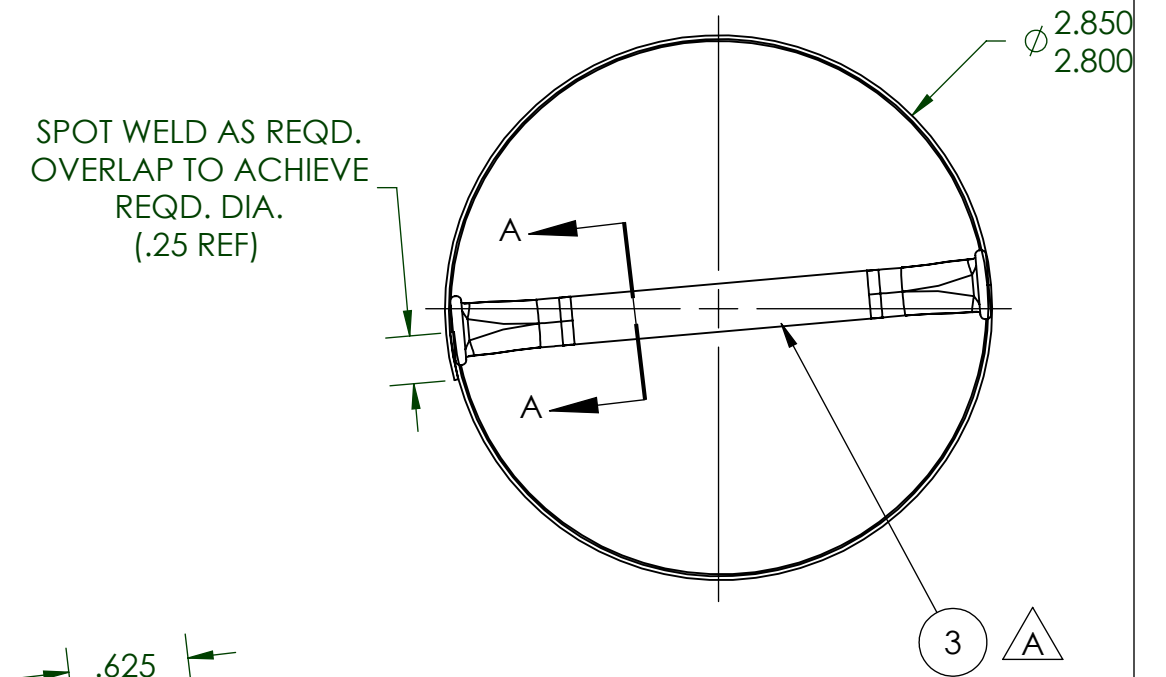
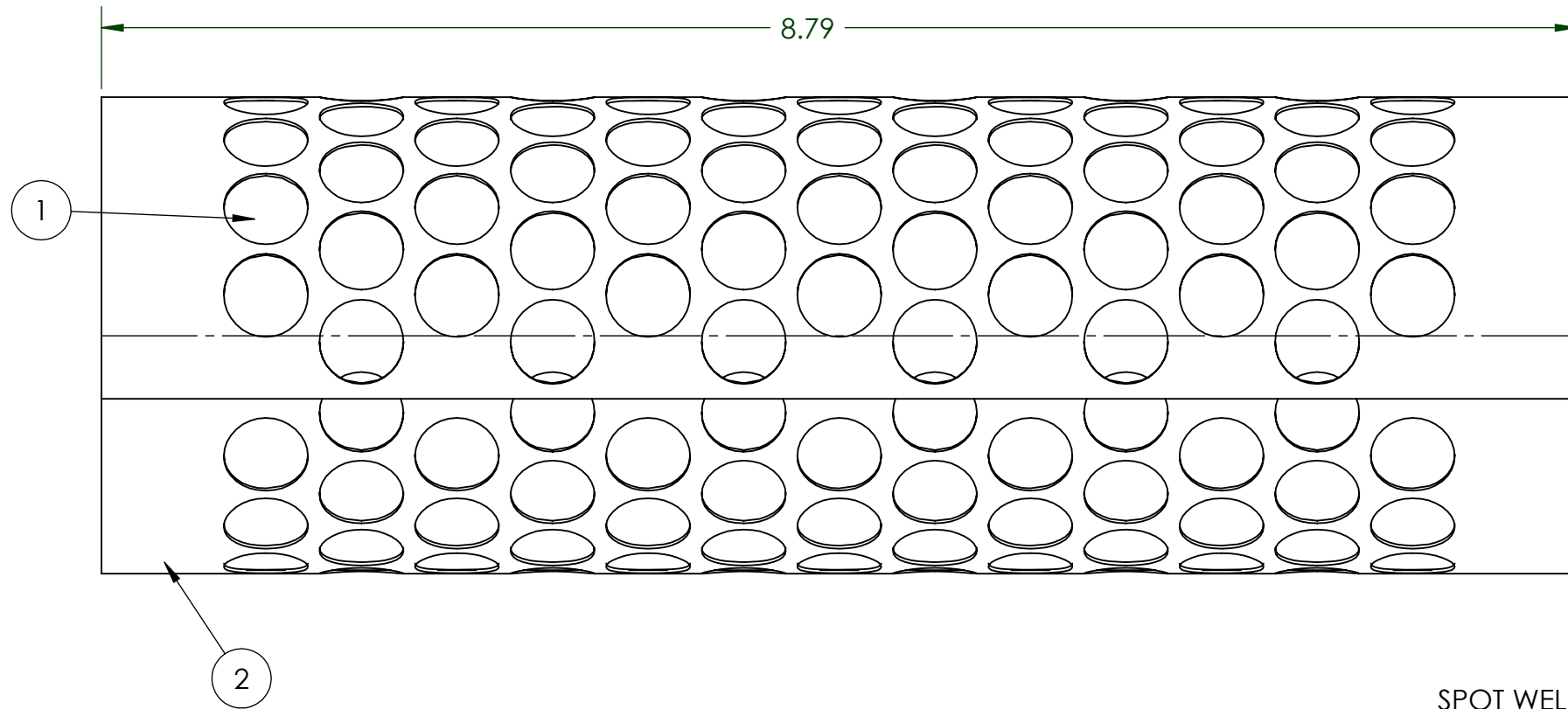

**ENGINEERING APPROVED COPY
FOR MANUFACTURE**

REV.	E.O.#	DESCRIPTION	BY	DATE	APPR'D	DATE
C	11137	REVERSED POSITION OF HANDLE 180°	LA	10/24/2017	CK	10/26/17
B	4845	ADDED PN-59202 TO NEXT ASSEMBLY	PK	10/8/2013		
A	3756	ADDED ITEM 3 P/N 19530 QTY 1 & SECTION "A-A"	PK	12/20/2012		

REVISIONS

NO. REQD.	NEXT ASSEMBLY	NAME	DATE
	59202	JMV	7-13-11
		RR	10/29/13
		CK	10/26/17

MATERIAL	FINISH
SEE BOM	SolidWorks
FINAL ASSEMBLY	
59136	

UNLESS OTHERWISE SPECIFIED:
DIMENSIONS ARE IN INCHES
TOLERANCES:
FRACTIONS ±1/16
.XX ±.03
.XXX ±.010
ANGLE ± 1/2°
HOLE DIA:
.0135 - .125 DIA. +.004 -.001
.1260 - .250 DIA. +.005 -.001
.2510 - .500 DIA. +.006 -.001
.5010 - .750 DIA. +.008 -.001
.7510 - 1.000 DIA. +.010 -.001

REMOVE ALL BURRS AND SHARP EDGES
INTERPRET DRAWING PER ANSI Y14.5M-1982
SURFACE ROUGHNESS PER MIL-STD-10
ALL MACHINED SURFACES NOT TO EXCEED 63 MICROINCHES PER MIL-STD-10 UNLESS NOTED

THIRD ANGLE PROJECTION



**TITLE: SCREEN ASSY - SST LINE STRAINER
40 MESH**

SIZE **B** DWG. NO. **29539** REV **C**

SCALE: 1:1 WEIGHT: SHEET 1 OF 1